

REVISIONS				
ZONE	LTR	DESCRIPTION	DATE	APRVD BY
ALL	A	Changed Part Number to: LTC18-7-1	10 July 2008	CED
ALL	B	Note added, Welding References Changed	06 June 2011	CED

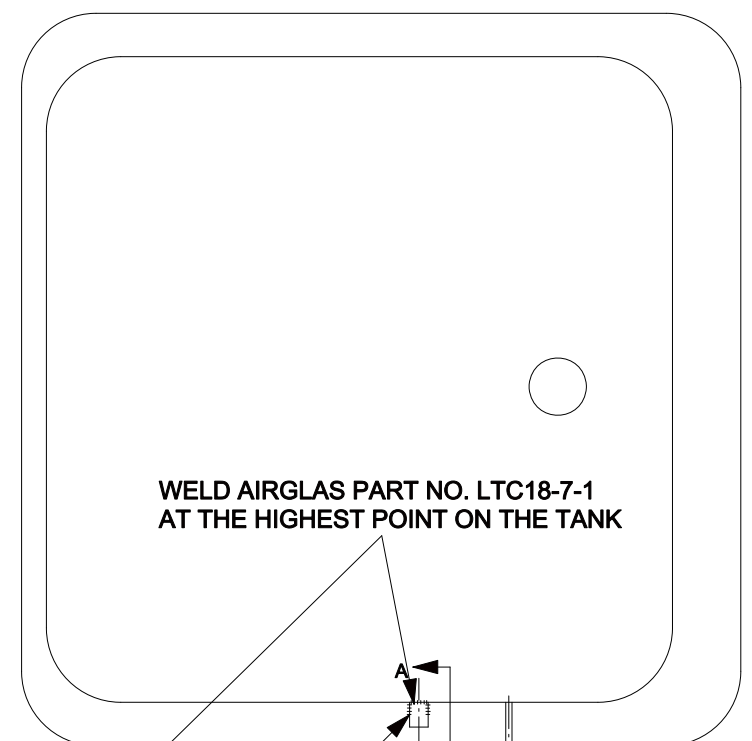

WELD AIRGLAS PART NO. LTC18-7-1  
AT THE HIGHEST POINT ON THE TANK

1 1/4  
3 5/8 ± 5/8

CL OF NIPPLE FOR UPPER FUEL  
SIGHT GAUGE HOSE

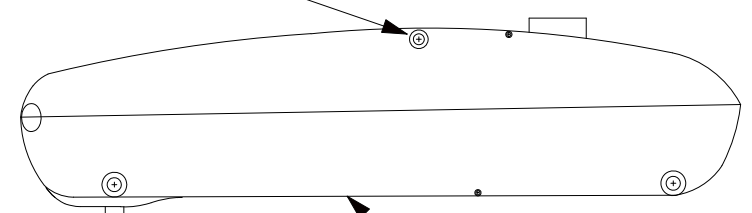

PA-18 LEFT WING TANK  
(PIPER P/N 10849-32)  
(PA18"150" DEPICTED,  
OTHERS SIMILAR)

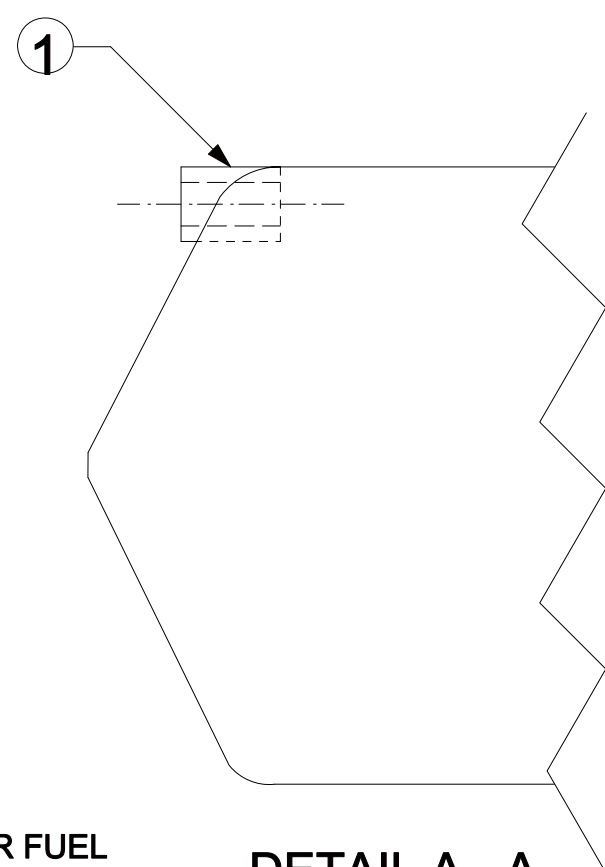

DETAIL A - A  
SCALE : 1 : 1

NOT TO SCALE

NOTES

1. WELD AIRGLAS PART NO. LTC18-7-1 TO PA-18 LEFT WING FUEL TANK BY TIG WELDING PROCESS USING 5052 ALUMINUM, .035 DIA. FILLER ROD CONFORMING TO MIL-E-16053L(1) OR LATER REVISION. ALL WELDING PRACTICES ARE TO BE IN ACCORDANCE WITH AC 43.13-1B, CHAPTER 4, SECTION 5, AND WITH AC 43.13-1B, CHAPTER 8, SECTION 2, PARAGRAPH 8-32 OR LATER REVISION.
2. AIRGLAS LTC18 CARGO POD INSTALLATION IS ELIGIBLE ONLY ON AIRPLANES EQUIPPED WITH SIGHT GAUGE TYPE FUEL QUANTITY INDICATORS.

NOTE: THIS DRAWING DEPICTS THE PA18"150". THIS DRAWING CAN BE USED AS A GENERAL REFERENCE FOR OTHER AIRCRAFT, HOWEVER COMPLIANCE WITH ALL REQUIREMENTS (i.e. FAA & MANUFACTURER) MUST BE MET.

THIS DRAWING INCLUDES INFORMATION PROPRIETARY TO AIRGLAS ENGINEERING CO., INC. AND SHALL NOT BE USED TO MANUFACTURE OR REPRODUCE WITHOUT PERMISSION OF AIRGLAS ENGINEERING CO., INC.

NO.	QTY	CODE IDENT. NO.	PART NUMBER	DESCRIPTION	STOCK SIZE	MATERIAL	MATERIAL SPEC.	UTS 1000	FINISH	CALC. UNIT	ACT. WT	ZONE
1	1		LTC18-7-1	FITTING	SEE DRAWING NO. LTC18-7-1							5D
LIST OF MATERIALS												
				UNLESS OTHERWISE SPECIFIED DIMENSIONS ARE IN INCHES	CONTRACT NO.		AIRGLAS, INC. Anchorage, Alaska					
				DECIMALS X ± .1 XX ± .03 XXX ± .010	SPEC. CONTROL NO.		WING TANK FITTING INSTALLATION					
				HEAT TREAT	Approved by: <b>WKL</b>							
				MATERIAL GOV. SPEC.	Checked by: <b>JDH</b>							
				STEEL MIL - H - 6875 ALUM. MIL - H - 6088 MAG. CAST MIL - H - 6857	Drawn by: Chris Donnelly							
NEXT ASSY. USED ON				APPLICATION		Date : 19 June 2008		Size Code Ident.No. <b>B 17564</b>		LTC18-7		REV <b>B</b>
								Scale 1 : 4 & NOTED		Sheet		1 of 1