

REVISIONS			
LTR	DESCRIPTION	DATE	APPROVED

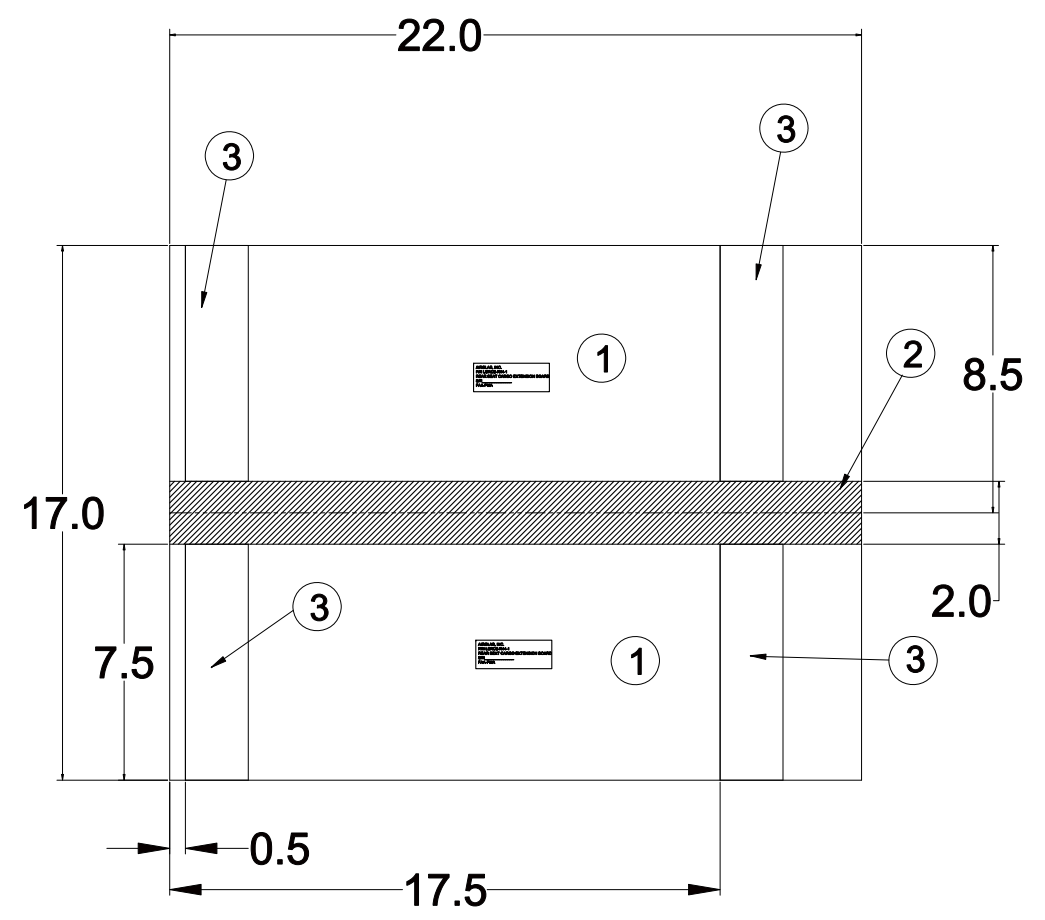

**LRSCE-R44 REAR SEAT CARGO EXTENSION
(BOTTOM SIDE DEPICTED)**

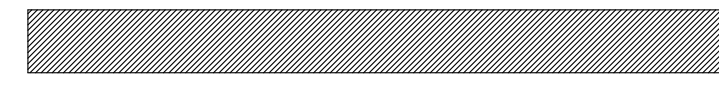

P/N 90198 LOOP SIDE VELCRO 2 IN. X 22 IN.



P/N 90198 LOOP SIDE VELCRO 2 IN. X 7.5 IN.

NO.	QTY	CODE-IDENT-NO	PART NO.	DESCRIPTION	NOTES
4	2	17564	90197	HOOK SIDE VELCRO	17" LENGTH
3	4	17564	90198	LOOP SIDE VELCRO	7.5" LENGTH
2	1	17564	90198	LOOP SIDE VELCRO	22" LENGTH
1	2	17564	LRSCE-R44-1	CARGO EXTENSION BOARD	
X	1	17564	LRSCE-R44	REAR SEAT CARGO EXTENSION	

LIST OF MATERIALS (PER CARGO EXTENSION)

THIS DRAWING INCLUDES INFORMATION PROPRIETARY TO AIRGLAS, INC. AND IS SUBMITTED FOR EVALUATION ONLY AND SHALL NOT BE USED TO MANUFACTURE OR REPRODUCE WITHOUT PERMISSION OF AIRGLAS, INC.

This document and the information disclosed herein are proprietary information of Airglas, Inc. Neither this document nor the information contained herein shall be transmitted, reproduced, copied, or disclosed in any form or by any means without the written authorization of Airglas, Inc.

The information disclosed herein includes trade secrets and confidential business and/or financial information and falls within exemption (b) (4) of 5 USC 552 (FOIA) and the prohibitions of 18 USC 1905.

UNLESS OTHERWISE SPECIFIED DIMENSIONS ARE IN INCHES		CONTRACT NO.		Airglas, Inc. Anchorage, Alaska	
DECIMALS: x.s.2 XXX.s.2		SPEC. CONTROL NO.			
ANGLES X° ± 8"		Approved by: JDH		LRSCE-R44 REAR SEAT CARGO EXTENSION	
HEAT TREAT MATERIAL GOV. SPEC.		Checked by: JDH			
STEEL MIL - H - 6875 ALUM. MIL - H - 6888 MAG. CAST MIL - H - 6857		Drawn by: CDB		Size	Code Ident.No.
Date: November 25, 2013		Scale: Do Not Scale		B	17564
				LRSCE-R44	REV
					(-)
				Sheet	2 OF 2