

REVISIONS			
REV	DESCRIPTION	DATE	APPROVED BY
A	ADDED FIFTH DZUS FASTENER TO SIDE DOOR.	10/10/2017	CDB

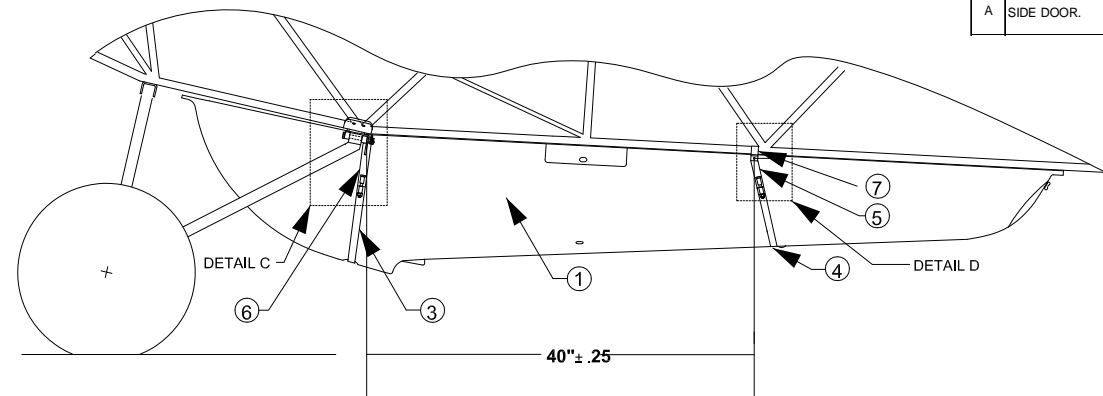
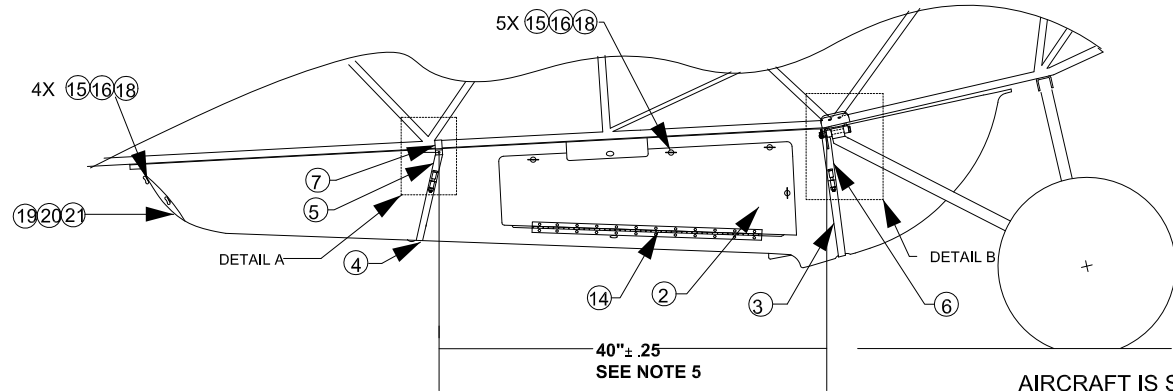

AIRCRAFT IS SHOWN RESTING ON THE GROUND WITH 8.50 x 6 TIRES INSTALLED

**NOTES**

- FOR INSTALLATION SEE AIRGLAS INSTALLATION MANUAL LC18XL-105.
- 81903-03 LANDING GEAR STEP ASSY. MUST BE REMOVED (IF PRESENT).
- ITEMS INSTALLED ON ITEM 1 AT FACTORY INCLUDED IN BILL OF MATERIALS FOR THE CONVENIENCE OF AIRCRAFT MAINTAINERS.
- UNLESS NOTED OTHERWISE, TORQUE ALL FASTENERS IAW AC 43.13-1B TABLE 7-1.
- IF SIDE BAGGAGE DOOR IS INSTALLED IN AIRCRAFT. MOVE ITEM 7 FORWARD TO CLEAR TUBING CLUSTER.

This document and the information disclosed herein are proprietary information of Airglas, Inc. Neither this document nor the information contained herein shall be transmitted, reproduced, copied, or disclosed in any form or by any means without the written authorization of Airglas, Inc.

The information disclosed herein includes trade secrets and confidential business and/or financial information and falls within exemption (b) (4) of 5 USC 552 (FOIA) and the prohibitions of 18 USC 1905.

This drawing includes information that is proprietary to Airglas, Inc. and shall not be used to manufacture or reproduce without the written authorization of Airglas, Inc.

NO.	QTY	CODE-IDENT-NO	PART NO.	DESCRIPTION	NOTES
21	2	17564	LTC18-2B-2	STRAP ASSY.	NOT DEPICTED. INSTALLED ON ITEM 1 AT FACTORY
20	2	17564	LTC18-2B-1	DOUBLER	NOT DEPICTED. INSTALLED ON ITEM 1 AT FACTORY
19	1	17564	LC18XL-2B	REAR DOOR	INSTALLED ON ITEM 1 AT FACTORY
18	9		S5A-200	SPRING	INSTALLED ON ITEM 1 AT FACTORY
17	8		RESERVED		
16	9		GA5-375	GROMMET	INSTALLED ON ITEM 1 AT FACTORY
15	9		AJ5-45	STUD, DZUS	INSTALLED ON ITEM 1 AT FACTORY
14	1		MS20257-4	HINGE (27" LONG)	INSTALLED ON ITEM 1 AT FACTORY
13	2		AN365-1032	NUT	ALT.: MS21042-3 OR MS21044N3
12	2		AN960-10	WASHER	ALT.: NAS1149F0363P
11	2		AN3-4A	BOLT	
10	4		AN365-428	NUT	ALT.: MS21042-4 OR MS21044N4
9	4		AN960-416	WASHER	ALT.: NAS1149F0463P
8	4	17564	AN4-24A OR MS90727-16	BOLT (MODIFIED)	
7	2	17564	LTC18-8	CLAMP	
6	2	17564	LTC18-6	STRAP ASSY.	
5	2	17564	LTC18-5	STRAP ASSY.	
4	1	17564	LC18XL-4	STRAP ASSY. CENTER REAR	
3	1	17564	LC18XL-3	STRAP ASSY. CENTER FRONT	
2	1	17564	LC18XL-2	SIDE DOOR	INSTALLED ON ITEM 1 AT FACTORY
1	1	17564	LC18XL-1	CARGO POD MOLDING	
X	1	17564	LC18XL	CARGO POD KIT	

**LIST OF MATERIALS**

UNLESS OTHERWISE SPECIFIED DIMENSIONS ARE IN INCHES		CONTRACT NO.		Airglas, Inc. Anchorage, Alaska	
DECIMALS .X ± .1 .XX ± .1 .XXX ± .1		SPEC. CONTROL NO.		LC18XL CARGO POD INSTALLATION	
ANGLES X ± 5°		Approved by: CDB		REV A	
HEAT TREAT		Checked by: CDB		Scale NOTED	
MATERIAL GOV. SPEC.		Drawn by: JDH		Sheet 1 OF 1	
STEEL MIL - H - 6875		Date: 6-8-2012		REV A	
ALUM. MIL - H - 6058					
MAG. CAST MIL - H - 6857					
NEXT ASSY.	USED ON	APPLICATION			

