

REVISIONS			
REV	DESCRIPTION	DATE	APPROVED BY
A	Minor Drafting Change	7/12/2018	JDH
B	Minor Drafting Change	8/7/2018	JDH
C	Corrected Tolerance	1/14/2019	JDH

NOTES:
 1. LEFT DEPICTED, RIGHT OPPOSITE.
 2. WHEN BACK DRILLING, SPOT THE BRACKET WITH THE APPROPRIATE DIAMETER DRILL. REMOVE THE BRACKET AND CAREFULLY FINISH WITH #9 DRILL TO PREVENT THE HOLE FROM WALKING.

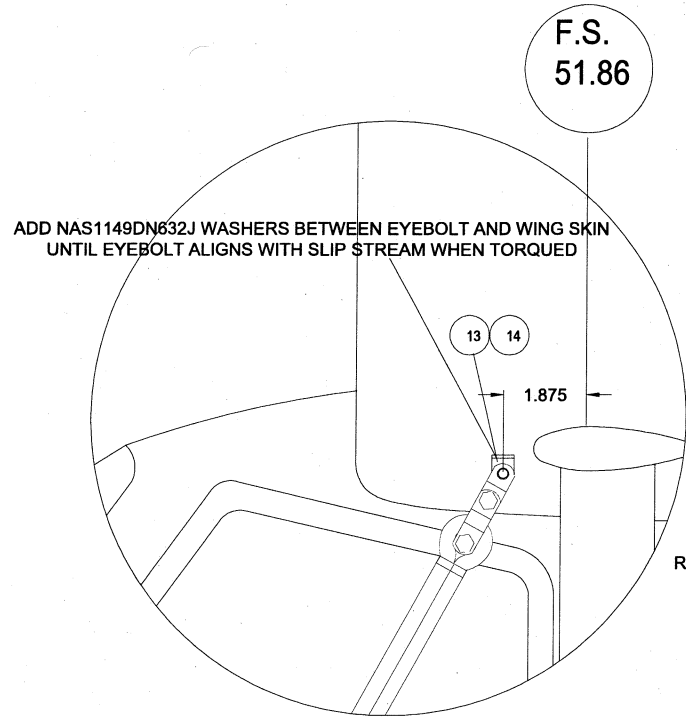

DETAIL D
 LEFT SHOWN
 RIGHT OPPOSITE

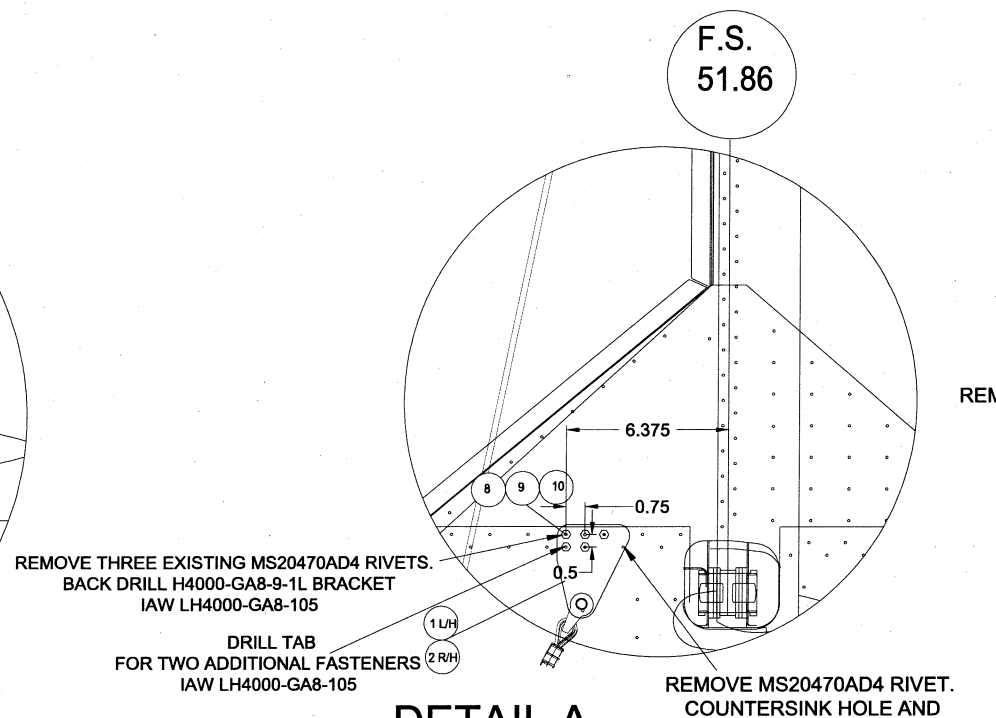

DETAIL A
 LEFT SHOWN
 RIGHT OPPOSITE

REMOVE THREE EXISTING MS20470AD4 RIVETS. BACK DRILL LH4000-GA8-9-2R BRACKET IAW LH4000-GA8-105

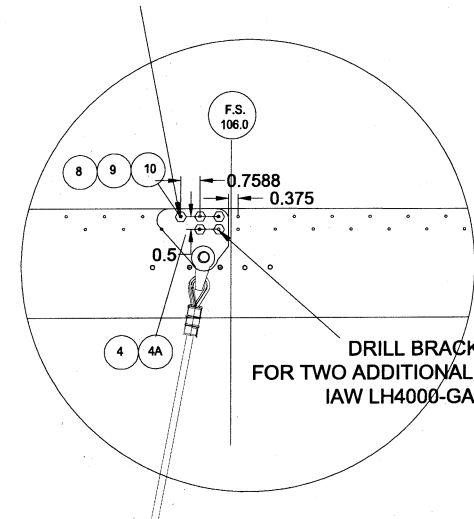

DETAIL C
 RIGHT CHECK CABLE

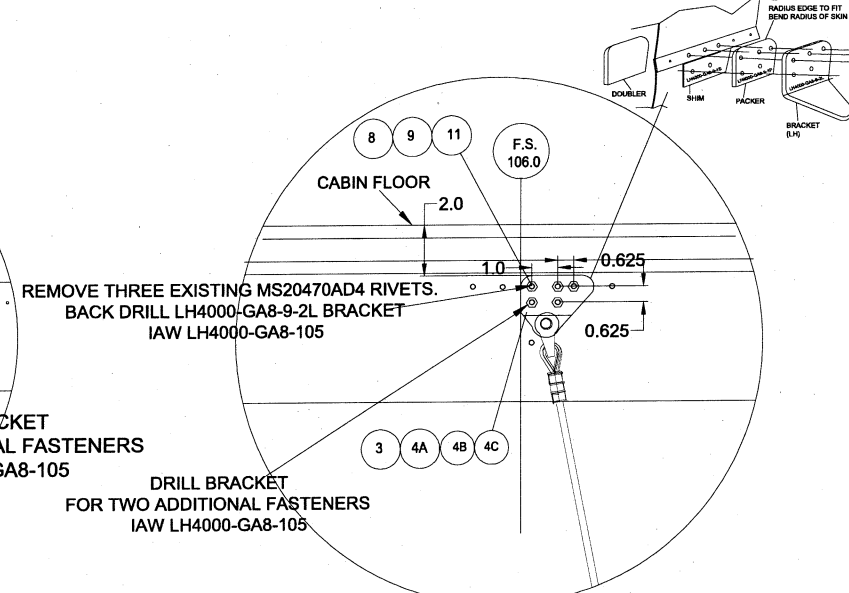

DETAIL B
 LEFT CHECK CABLE

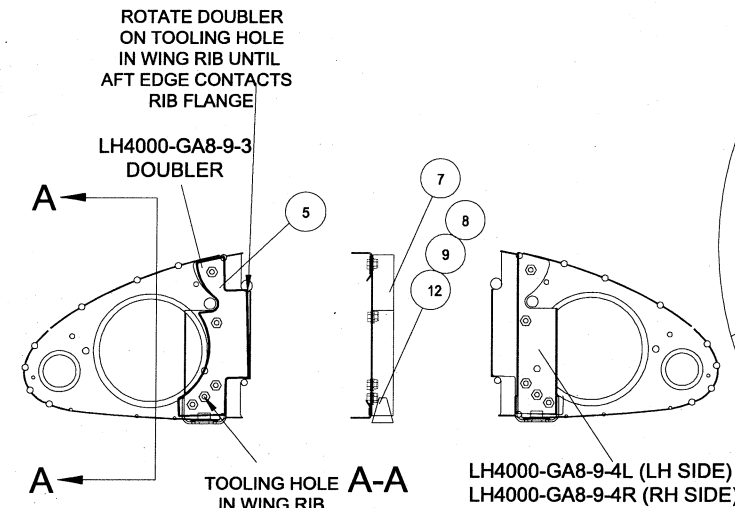

BUNGEE ATTACH BRACKET IN WING
 LH SHOWN-RH OPPOSITE

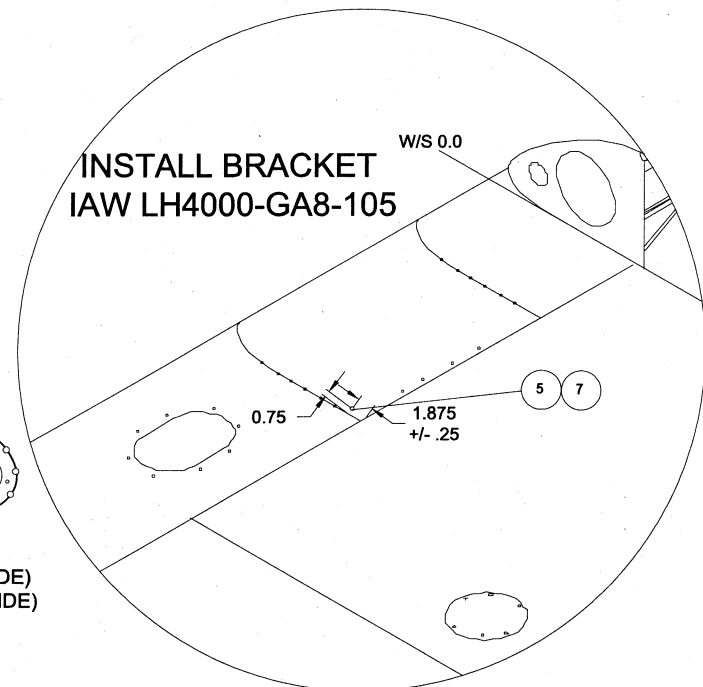

DETAIL E
 RIGHT SHOWN
 LEFT OPPOSITE

NO.	QTY	CODE-IDENT-NO	PART NO.	DESCRIPTION	NOTES
14	2		AN46-6A	EYE BOLT	
13	AR		NAS1149DN632J	WASHER	
12	10		AN3-4A	BOLT	
11	5		AN525-10R12	SCREW	
10	15		AN525-10R10	SCREW	
9	30		NAS1149FN363P	WASHER	AN960-3 ALTERNATE
8	30		MS21044N3	NUT	MS21045-3 ALTERNATE
7	1	17564	LH4000-GA8-9-4R	CHANNEL BRKT ASSY(RH)	NOT SHOWN
6	1	17564	LH4000-GA8-9-4L	CHANNEL BRKT ASSY(LH)	
5	2	17564	LH4000-GA8-9-3	WING DOUBLER	
4C	1	17564	LH4000-GA8-9-1P	PACKER (LT SIDE ONLY)	
4B	1	17564	LH4000-GA8-9-1S	SHIM (LT SIDE ONLY)	
4A	2	17564	LH4000-GA8-9-1D	DOUBLER	
4	1	17564	LH4000-GA8-9-2R	BRACKET (RH)	
3	1	17564	LH4000-GA8-9-2L	BRACKET (LH)	
2	1	17564	LH4000-GA8-9-1R	BRACKET (RH)	NOT SHOWN
1	1	17564	LH4000-GA8-9-1L	BRACKET (LH)	
LIST OF MATERIALS (QTY FOR ONE SKI KIT)					

UNLESS OTHERWISE SPECIFIED DIMENSIONS ARE IN INCHES

CONTRACT NO. _____
 SPEC. CONTROL NO. _____

HEAT TREAT: X2 1, X2 2, X2 3, XXX 1, 010

MATERIAL: STEEL, ALUM., MAG. CAST
 GOV. SPEC: MIL - H - 6875, MIL - H - 6888, MIL - H - 6857

Approved by: JDH
 Checked by: JDH
 Drawn by: CDB
 Date: FEB 14, 2018

Airglas, Inc.
 Anchorage, Alaska
 GLH3000 NOSE AND
 LH4000 MAIN SKI INSTALLATION
 ON
 GIPPSAERO GA8 SERIES

Size Code Ident No. B 17564
 Part No. LH4000-GA8
 Scale: Do Not Scale
 Sheet 2 OF 10