

REVISIONS			
REV	DESCRIPTION	DATE	APPROVED BY
A	Minor Drafting Change	7/12/2018	JDH
B	Minor Drafting Change	8/7/2018	JDH
C	Corrected Tolerance	1/14/2019	JDH

NOTES:

1. INSTALL WHEEL AND ADJUST BEARING PRELOAD WITH BUCKETS. SAFETY BUCKETS TO FORK USING .032 OR THICKER SAFETY WIRE.
2. INSTALL WASHERS BETWEEN FORK AND YOKE ROD ENDS AS REQUIRED.
3. SAFETY BOLTS WITH .032 SAFETY WIRE.

NOSE FORK SKI COMPONENTS

AIRGLAS PART NO.
AIRGLAS SERIAL NO.

AIRGLAS PART NO.
AIRGLAS SERIAL NO.

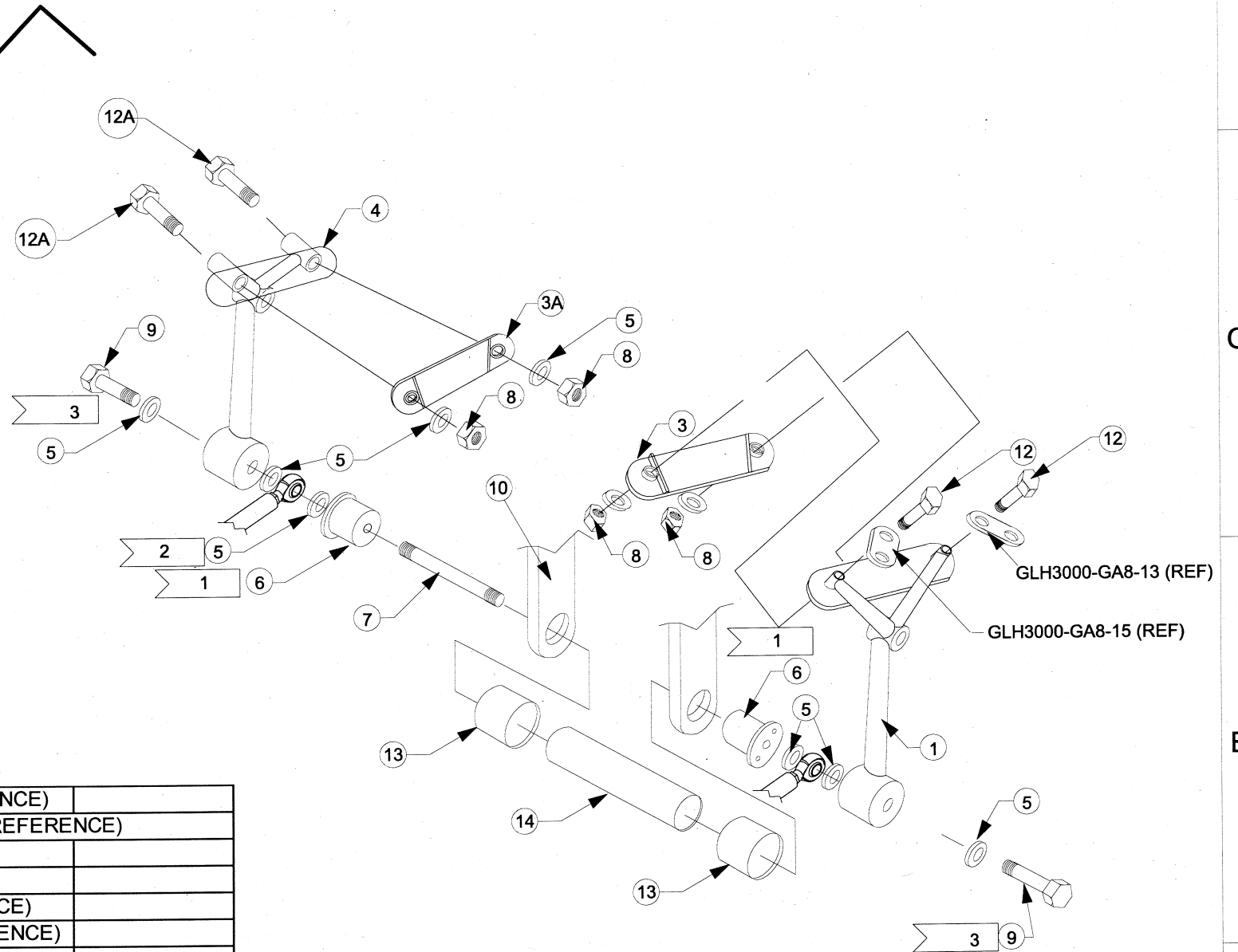
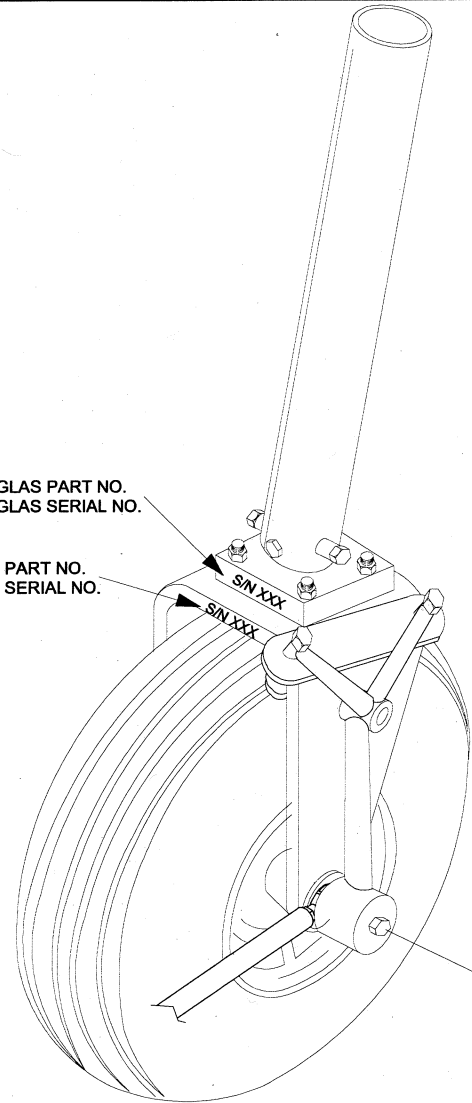

NO.	QTY	CODE-IDENT-NO	PART NO.	DESCRIPTION	NOTES
14	1	17564	PA32-206L-2	AXLE TUBE (REFERENCE)	
13	2	17564	PA32-206L3	BEARING SPACER (REFERENCE)	
12A	2		AN6-23A	Bolt	
12	2		AN6-24A	BOLTS	
11	2	17564	HMX6G	ROD END (REFERENCE)	
10	1	17564	PA32-206LA-1	NOSE FORK (REFERENCE)	
9	2		AN6H23A	BOLT	
8	4		MS21045N6	NUT	
7	1	17564	PA32-206L-4-GLH	AXLE ROD	
6	2	17564	PA32-206L-6-GLH	BUCKET	
5	10		NAS1149F0663P	WASHER	
4	1	17564	GLH3000-NG-LR1-2	ATTACH PLATE	
3A	1	17564	GLH3000-NG-LR1-2R	DOUBLER RIGHT HAND	
3	1	17564	GLH3000-NG-LR1-2L	DOUBLER LEFT HAND	
2		RESERVED			
1	1	17564	GLH3000-NG-LR1-1	ATTACH PLATE	
X		17564	GLH3000-NG-LR1	SKI RIGGER ATTACH KIT	
NO.	QTY	CODE-IDENT-NO	PART NO.	DESCRIPTION	NOTES

LIST OF MATERIALS

UNLESS OTHERWISE SPECIFIED DIMENSIONS ARE IN INCHES		CONTRACT NO.		Airglas, Inc. Anchorage, Alaska	
X ± .1 XX ± .03 XXX ± .010		SPEC. CONTROL NO.			
HEAT TREAT MATERIAL GOV. SPEC.		Approved by: JDH		GLH3000 NOSE AND LH4000 MAIN SKI INSTALLATION ON GIPPSAERO GA8 SERIES	
STEEL MIL - H - 6875 ALUM. MIL - H - 6088 MAG. CAST MIL - H - 6857		Checked by: JDH			
NEXT ASSY. USED ON		Drawn by: CDB		Size Code Ident.No. B 17564 LH4000-GA8	
APPLICATION		FEB 14, 2018		REV C	
		Scale: DO NOT SCALE		Sheet 4 of 10	